



▶ Mounted Field Sprayer  
**Sirius**





**Plant protection today**





Today, a growing number of farmers seek to optimise the intensity of inputs in order to maximise the advantages of prevailing weather and crop rotation. Together with the high yield expectations available from modern crop varieties, this requires a reliable, user-friendly and precise sprayer to apply plant protection chemicals and liquid fertiliser.

A successful plant protection program is one of the most important requirements for a good harvest. Innovative and efficient field sprayers support the professional crop production specialist in the daily challenge of reducing costs and increasing yields while simultaneously protecting the environment.



When it comes to plant protection, the farmer is monitored by the public and inspected by the authorities. Public opinion on the subject of protection of the environment can be positively influenced by managing plant protection responsibly. For these reasons, a modern field sprayer must offer reliability, safe operation, and easy cleaning.

With its new Sirius sprayer range, LEMKEN offers the best conditions to successfully master these challenges. The Sirius is the first field sprayer series which has been designed and constructed completely by LEMKEN. This new design combines user-friendliness with ease of operation and optimised functionality. The outer shape characterises the compact design of the Sirius.

# Powerful, reliable, compact



A field sprayer has to be able to accurately apply a wide range of application volumes according to the requirement of the chemical being applied. Often a high water volume is required for a successful result. Depending on the size and location of the fields, the use of a trailed field sprayer with a large tank volume may not be the perfect solution.

The compact mounted field sprayers of the LEMKEN Sirius series, with a useable tank capacity up to 1,900 litres, guarantee maximum area coverage and high manoeuvrability. The close centre of gravity of the Sirius reduces lift requirement and improves tractor stability even where a large volume is carried on the 3 point linkage.

The tank, which is only 55 centimetres from front to rear, contributes to this optimum centre of gravity and is fitted to all Sirius models. As a result of this, and the integrated tank baffle, the tractor / machine combination can be driven safely, and is easy to handle in small fields and on slopes.

Other highlights of the Sirius mounted field sprayers are the innovative Quick-Connect system which allows the field sprayer to be coupled and decoupled from the tractor quickly and safely, and the excellent contour following ability of the SectionExtend SE or HorizontalExtend HE boom.

The Sirius mounted field sprayer range includes two series. Sirius 7 is equipped with in-cab controls for spraying pressure and section controls. Sirius 9 has the additional feature of full in-cab control of application rate, which is maintained over a range of forward speeds. Working widths of 12 to 24 metres and useable tank volumes of 900, 1,300, 1,600 and 1,900 litres mean there is a model to suit farms and tractors of most sizes.



# Range of models at a glance

## ▶ Sirius with 900-litre tank volume

- Available with HE boom in working widths of 12 - 15 metres or with SE boom in working widths of 15 - 24 metres
- Electronically remote-controlled as Sirius 7, or electronically and automatically controlled application rate as Sirius 9
- In the picture: Sirius 7/900 HE 15



## ▶ Sirius with 1,300-litre tank volume

- Available with HE boom in working widths of 12 - 15 metres or with SE boom in working widths of 15 - 24 metres
- Electronically remote-controlled as Sirius 7, or electronically and automatically controlled application rate as Sirius 9
- In the picture: Sirius 9/1300 SE 15/11



## ▶ Sirius with 1,600-litre tank volume

- Available with SE boom in working widths of 15 - 24 metres
- Electronically remote-controlled as Sirius 7, or electronically and automatically controlled application rate as Sirius 9
- In the picture: Sirius 9/1600 SE 21/17



## ▶ Sirius with 1,900-litre tank volume

- Available with SE boom in working widths of 15 - 24 metres
- Electronically remote-controlled as Sirius 7, or electronically and automatically controlled application rate as Sirius 9
- In the picture: Sirius 9/1900 SE 21/15



# Convenience and Safety



## ▶ The innovative QuickConnect coupling system



QuickConnect, the automatic upper link coupling system from LEMKEN, combines two important advantages which are mutually exclusive with all coupling systems used previously on tractors with fully-mounted machines.

- The QuickConnect system allows adequate clearance between tractor and machine so that all connections and services such as PTO shaft, hoses,

cables and upper links can be connected conveniently and safely.

- The innovative QuickConnect coupling system automatically positions the machine so close to the tractor that even high-volume mounted machine such as the LEMKEN Sirius mounted sprayer with a large tank can be used with minimum front ballast.
- The QuickConnect system means that the operator no longer has to drag heavy parts, such as a coupling triangle, into the three-point linkage of the tractor.
- These advantages in performance and the improvement in functional safety were awarded a silver medal for innovation by the DLG at Agritechnica 2009.







### Top-of-the-range tank

- If a large tank capacity is to be carried safely, a sprayer has to be designed to keep its centre of gravity as close as possible to the tractor. The tank shape of the Sirius series from LEMKEN is setting new standards as it is only 55 cm deep over the overall height keeping the weight close to the tractor.
- To prevent the tractor from veering to the side in the direction of travel when the tank is partially filled, an integral baffle (1) has been cast directly into the Sirius tank.
- There are no areas shadowed from cleaning nozzles, and the tank can be cleaned quickly and in an environmentally friendly manner. Driving safety is therefore combined with convenient handling.



### Intelligent internal cleaning process

- A sophisticated cleaning concept ensures that the high internal walls of the Sirius and the tank partitioned by the baffle are always perfectly cleaned.
- When working in the field, the tank is kept moist by re-circulated liquid during headland turns. The system also ensures that the pressure is maintained at the spray valves for use after the headland turn.
  - Four high pressure rotating plastic cleaning nozzles, arranged optimally in the tank, ensure that the tank is cleaned as effectively as possible with clear water after the spraying process.



### Rigid frame structure

- To cope with the hard practical operating conditions in agriculture, the Sirius features a solid frame structure.
- Steel profiles with a large diameter and a completely closed frame guarantee high stability.
  - As the tank is only 55 cm deep, the centre of gravity of the frame is close to the tractor.
  - The hose cabinet integrated in the frame ensures that hydraulic hoses and cables (2) are stored cleanly and tidily after they have been decoupled from the tractor.



# Operation made easy



## ▶ Control panel, Sirius 7

The Sirius 7 control panel brings all functions neatly together on the left hand side of the machine. Control valves, induction hopper and hand-wash tank are easily accessible. Single-lever operation of the suction and pressure functions make operation simple and convenient.

- All filling connections are arranged on the filling bar without any risk of a mix-up.
- The valves are identified by clear symbols to prevent operating errors.



## ▶ Simple operation with Easyspray

The electronically remote-controlled Sirius 7 is the entry-level version of the Sirius series. With the innovative LEMKEN Easyspray control terminal, all important functions of the Sirius can be operated reliably from the tractor seat. The range of functions includes:

- Boom folding by one-hand control with pre-selection.
- On and off control of spray function, and switching of up to 9 boom sections.
- Bypass control, this means circulation of the spray agent up to the section control valves on the centrepiece.



- Setting the spray pressure with integrated digital pressure indicator.
- Controlling the hydraulic functions of the spray boom (folding in and folding out, one-sided folding).
- Pre-selecting switching of symmetrical folding.
- Operating the additional functions such as working light, warning beacon and slope compensator as well as indicators for horizontal position of the boom and active pendulum lock.







### Control panel, Sirius 9

The control panel of the Sirius 9 corresponds in all functions to the control panel of the Sirius 7, but is extended by the following functions:

- Selection valve which allows the tank to be filled via the pump.
- An electronic level indicator is optionally available.
- The control panel of the Sirius 7 and the Sirius 9 is protected from dirt by a cover. The cover is opened and closed with the aid of a gas-pressure damper.



### Convenient operation with Ecospray

The fully electronic Sirius 9 is operated via the LEMKEN Ecospray control terminal. Application rate is simply set, with the control box automatically maintaining it over a range of forward speeds. The standard Ecospray control box makes it easy to set rate, and control sprayer functions via push button and rotary control knob. Optionally a 'switch' panel (1) is available for control of sections if preferred. The range of functions includes:

- Boom folding by one-hand control with pre-selection.
- Diagnostics mode for the SectionExtend boom to check the safety sensor technology.



- Bypass control - this means circulation of the spray agent up to the partial width valves.
- Continuous pressure and flow rate indicator.
- Switchover from manual to automatic pressure control.
- Higher/lower rate control by pressing button.
- Remaining amount indicator (mathematical, e.g. in hectares or by distance).
- Hectare counter, litre counter, working time counter.
- Input-dependent level monitor.



# SectionExtend High Specification boom



## Stable and light - SectionExtend boom SE

The Sirius can be fitted with the new SectionExtend SE boom generation. The three and four-part boom folded behind the machine, manufactured from proven torsion-resistant aluminium tubing, combines strength with nozzle protection.

- This results in a light boom with improved pendular performance which ensures a uniform application of the active ingredients.
- The SectionExtend boom is guided in the parasol frame. The adjustable pivot below or above the boom centre of gravity allows boom movement to be optimally adjusted for all operating conditions.
- The SectionExtend aluminium tubular booms are offered in working widths of 15, 18, 21 and 24 metres. They can be reduced symmetrically, e.g. from 24 to 18 metres or from 21 to 15 metres (see diagram below).

### Working width/symmetrically reduced - number of partial widths

15/11 m - 5

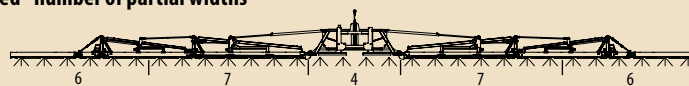

### Partial width division

3/3,5/2/3,5/3 m

18/13 m - 5

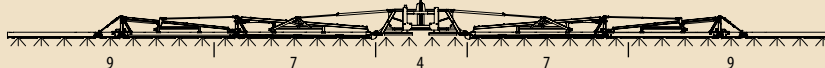

4,5/3,5/2/3,5/4,5 m

21/17 m - 7



3/3/3,5/2/3,5/3/3 m

21/15 m - 7



3/3/3,5/2/3,5/3/3 m

24/18 m - 7



3/3/5/2/5/3/3 m

SE boom with nozzle division (view from rear)





**▶ Parasol = Perfectly attached**

The attachment of the boom in the parasol frame fulfils all demands for the highest damping quality. The boom is maintained parallel to the ground to ensure very uniform distribution of liquid across the working width.

- The automatic parallel adjustment ensures optimum working even on slopes.
- In addition, highly effective horizontal vibration dampers ensure precise longitudinal distribution.



**▶ Slope and obstruction specialist**

A hydraulic slope compensator is available for extreme slopes, and asymmetrical folding if required. The slope compensator is actuated via the pre-selection hydraulics with the same double-acting spool valve as the folding.

- Optionally, asymmetrical folding is available, on the SectionExtend boom, to reduce the working width in case of obstacles (Fig. 1).

- A pendulum lock and a slope compensator hold the asymmetrical boom at the correct distance over the crop.
- On slopes the individual booms can be upwardly angled by 15° (Fig. 2). The variable geometry of the SE linkage makes the Sirius the genuine slope and obstruction specialist.

Width of the boom (on left or right)

4 m  
4 m  
9 m

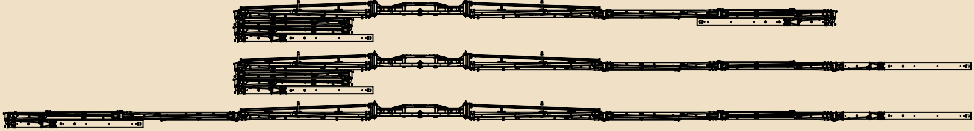

Width of the boom (on left or right)

9 m  
12 m  
12 m

Fig. 1 Asymmetrical folding options of the SE boom 24/18 (view from above)

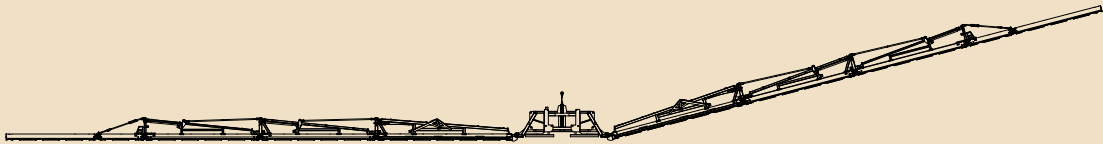

Fig. 2 SE boom upwardly angled by 15° (view from rear)

# SectionExtend - the ultimate boom



▶ **Narrow and safe for road transport**

The SectionExtend boom is hydraulically folded in and out.

- The boom folds neatly into a package behind the tank for transport.
- A transport width of only 2.33 to 2.43 metres (depending on the working width of the boom) is achieved.
- The SE boom is parked in the lowest position for safe transportation and a low centre of gravity.



▶ **Optimally protected**

Spray lines and nozzles are carried within the aluminium tubing to provide optimum protection from damage.

- The boom tubing offers adequate space for triplex nozzle holders.
- A bypass control circulates the spray agent up to the partial width valves on the centrepiece.



▶ **Best bumpers**

The SectionExtend boom is fitted with break-backs on the outer sections.

- The boom ends can avoid obstacles by moving forwards and backwards up to 85° (1). Therefore the main booms are protected from mechanical overload over the entire length.
- The boom ends can avoid obstacles by moving upwards up to 50° (2). As a result, the boom ends return very quickly to the working position after avoiding an obstacle. Furthermore, when they come into contact with the ground, they do not transfer shock loads to the rest of the sprayer boom.

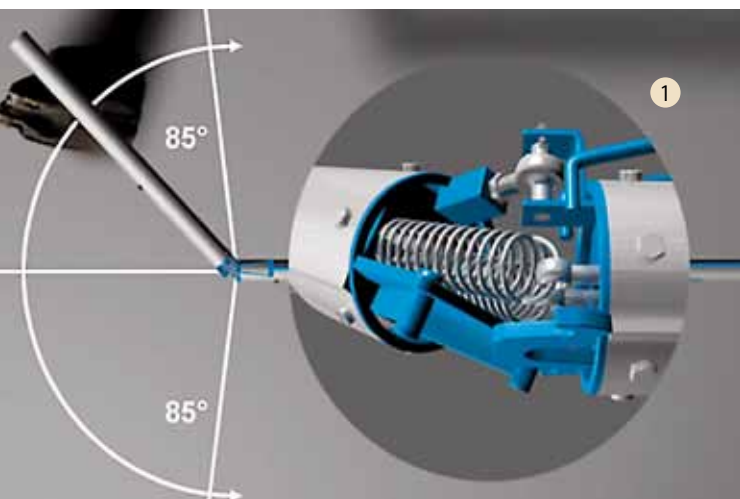



# HorizontalExtend boom - a solid boom with narrow working widths



## ▶ Solid and proven - HorizontalExtend boom HE

The new, hydraulically folding HorizontalExtend boom is a further development of the proven SPH boom.

- The HorizontalExtend boom is also held in the parasol frame in the same way as the SectionExtend boom. The adjustable pivot below or above the linkage centre of gravity allows the oscillation to be optimally adjusted for all operating conditions.
- Adjustable stops on the main joints as well as robust break-back joints at the outside guarantee a long service life.
- Single side folding is possible, with the manual pendulum lock being used to hold the boom parallel to the ground.

- If fitted with the hydraulic slope adjustment with hydraulic pendulum lock, the boom can be adjusted by remote control from the tractor cab to the terrain conditions. Angle selected is displayed on the control box.
- The HorizontalExtend booms are offered in working widths of 12 and 15 metres. Asymmetrical folding is available as an option.

## ▶ Narrow and safe for road transport

The HorizontalExtend boom is folded in and out fully automatically using the hydraulic cylinder.

- The boom folds to 3m transport width.
- Booms are locked in the transport position by electromagnetic valves on the folding cylinders.

### Working width – Partial widths

12 m - 5

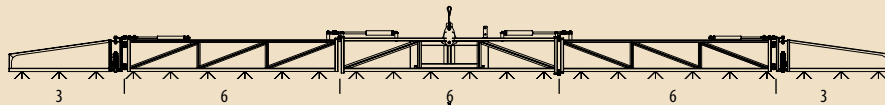

### Partial width division

1,5/3/3/3/1,5 m

15 m - 5

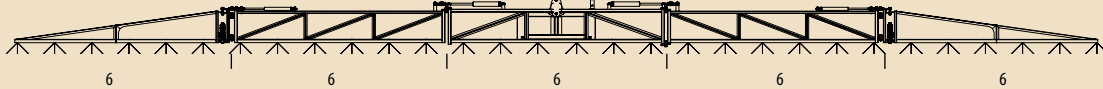

3/3/3/3/3 m

HE boom with nozzle division (view from rear)

## With optimum features



### Easy to fill

All Sirius models have an external filling connection with a  $\frac{3}{4}$  inch Geka connection as standard.

- This connection enables the tank to be filled via an external pressure source, e.g. the water mains.
- A one-way valve prevents water from flowing back to the source. To speed up filling, e.g. via a hydrant, this connection can be optionally fitted with a 2-inch Kamlok coupling or C-coupling.
- Suction-filling is possible with the Sirius 9, and available as an option on the Sirius 7.



### Adequate clean water

The clean water tank positioned at the side under the main tank is designed to hold max. 170 litres of clean water.

- The tank contents can be used to clean canisters, interiors and exteriors, or to dilute the technical residue. The clean water can also be used to clean out pump and spray lines when the tank is still partially filled.
- The clean water tank has a level indicator and is filled through a hole in the top or the Geka connection.
- The clean water tank is mounted at a low level helping to reduce the overall centre of gravity of the machine.







**Dissolve and flush cleanly**

In the case of pesticides which are difficult to dissolve, the Sirius induction hopper with integrated rinse shows its strengths.

- The Proflow nozzle enables the agents to be mixed uniformly and flushes them directly into the tank.
- The large opening, with central canister rinse nozzle, allow easy cleaning of pesticide cans.
- The induction hopper folds neatly under the control panel when not in use.

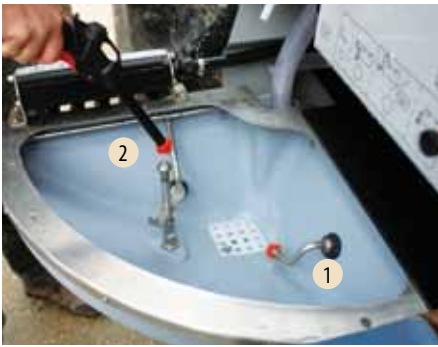

**Agitator nozzle and canister cleaning gun**

Powder-based pesticides can be difficult to dissolve, so require an efficient system to ensure they are dissolved completely in the tank.

- The optional agitator nozzle (1) keeps powders moving in the induction hopper to help them dissolve completely into the water prior to transfer to the main sprayer tank.
- Large pesticide cans may be cleaned with the canister cleaning gun (2), which is available as an accessory.



**Pressure filter/agitator switching**

The Sirius benefits from variable agitation as standard. Using the agitator control (4), the operator can select the appropriate level of tank agitation for the chemical being used.

- The Sirius pressure filter is also optimally positioned in the upper right area of the control panel (3). In this position it is easy for the user to open and remove it for cleaning.
- To clean the filter even when the tank is filled, the agitator is switched off and the filter is drained.
- Tank remains can be pumped out of the spray tank via the standard pump-out connection. A safety handle (4) makes an operating error difficult.



# Perfected down to the last detail



## Protected lines

All supply lines are routed through, and protected by, the so-called energy chain (1) above the tank. This effectively prevents the flexible supply lines from bending or becoming pinched.

- Restrictions to pendulum movement, by excessively short lines, are excluded.
- The energy chain also offers protection against mechanical overload, e.g. contact with trees.



## Clean hands

On the side of the tank is a hand washing tank for 20 litres of fresh water.

- Hands can be washed frequently using this water supply.
- The hand washing tank is independent of the main sprayer system to avoid the risk of contamination.







### Protection of the crop

When spraying tall crops, the plants, which have already been disturbed by the tractor, should be protected from further damage by the field sprayer.

- This requirement is fulfilled by the optionally available deflector (1) which makes the underside of the device a uniform and smooth area.
- To facilitate access to the pump for maintenance and to simplify cleaning, the plastic deflector can easily be removed by loosening just two screws.



### Park safely and transport easily

To park the Sirius safely, it is fitted with hinged parking supports (2). These can be easily folded from the parking to the field position and are automatically secured in place.

- For smooth and level yard areas four transport rollers (3), which are available as accessories, can be attached to the parking supports. Two of the transport rollers are braked and two rollers can be steered.
- All Sirius models have fork lift tine locating points (4) as standard to allow easy and safe movement when not fitted to the tractor.



### Exterior cleaning made easy

The requirements of the Cross Compliance regulations permit the outer areas of the field sprayer to be cleaned only on unpaved ground without access to a water course.

- To clean the exterior in compliance with the regulations, a 15 metre hose reel with connection for the spray pump is optionally available.
- At a max. pressure of 10 bar, spray agent residue and dirt can be easily and effectively washed off the sprayer directly onto the field.
- Positioning the hose centrally on the machine means it can also be used to rinse the unfolded booms.



# Technical data

Weight (in kg)					
		Sirius 7 and 9			
with boom		900	1300	1600	1900
HorizontalExtend HE 12		1,068	1,103	-	-
HorizontalExtend HE 15		1,088	1,123	-	-
SectionExtend SE 15/11		1,205	1,240	1,455	1,545
SectionExtend SE 18/13		1,225	1,260	1,475	1,565
SectionExtend SE 21/15		1,320	1,355	1,570	1,660
SectionExtend SE 21/17		1,320	1,355	1,570	1,660
SectionExtend SE 24/18		1,400	1,435	1,650	1,740

Volume (in l)					
Tank , nominal volume		900	1,300	1,600	1,900
Tank, actual volume		950	1,370	1,680	2,000
Clear water tank		170	170	170	170
Hand washing tank		20	20	20	20

Coupling dimensions					
		Cat, 2	Cat, 2	Cat, 3N=L2 Z3	Cat, 3N=L2 Z3

Height of tank (in mm, measured from lower edge of device)					
		1,790	2,060	2,340	2,590

Transport dimensions (in mm)						
		Height of Sirius 7 and 9				
with boom	Length	Width	900	1300	1600	1900
HorizontalExtend HE 12	1,750	2,998	2,800	3,030	-	-
HorizontalExtend HE 15	1,750	2,998	2,800	3,030	-	-
SectionExtend SE 15/11	2,080	2,333	3,170	3,170	3,170	3,170
SectionExtend SE 18/13	2,080	2,333	3,300	3,300	3,300	3,300
SectionExtend SE 21/15	2,080	2,436	3,170	3,170	3,170	3,170
SectionExtend SE 21/17	2,080	2,333	3,170	3,170	3,170	3,170
SectionExtend SE 24/18	2,080	2,370	3,440	3,440	3,440	3,440

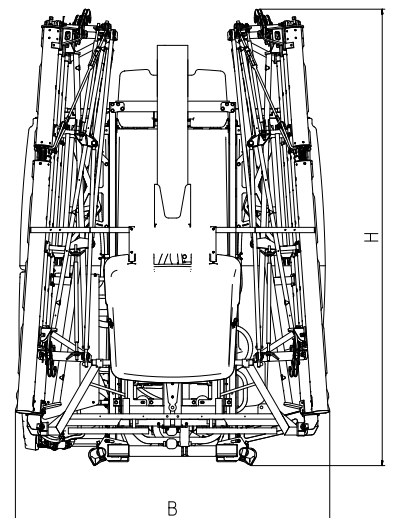
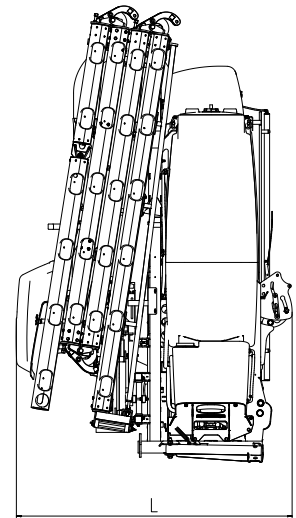

## Basic equipment of Sirius 7

Electronic remote control LEMKEN Easyspray for 5 - 9 partial widths; electro-hydraulic basic folding with hydraulic height adjustment (symmetrical folding of the booms and pendulum lock for SE boom only); digital pressure display; integrated baffle; QuickConnect quick coupling system (900/1300: Cat. 2, 1600/1900: Cat. 3N=L2 Z3); piston diaphragm pump flow rate 226 litres/min; 170-litre clear water tank; 20-litre hand washing tank; self-cleaning pressure filter; external filling connection GEKA coupling for main tank and fresh water tank; single-lever operation in the pressure area; indirect level indicator; flushing sluice with edge moistening, canister flushing and Proflow nozzle in the outlet; internal cleaning of tank; variable agitation; single nozzle holder; section control with pressure balancing; circulation up to the section control valves on the centrepiece; receiving pockets for fork lifts.

## Basic equipment of Sirius 9

Electronic remote control and automatic rate control with LEMKEN Ecospray Computer with 5 - 9 partial widths; electro-hydraulic basic folding with hydraulic height adjustment (symmetrical folding of the booms and pendulum lock for SE boom only); digital pressure display; integrated baffle; QuickConnect quick coupling system (900/1300: Cat. 2, 1600/1900: Cat. 3N=L2 Z3); piston diaphragm pump flow rate 226 litres/min; 170-litre clear water tank; 20-litre hand washing tank; self-cleaning pressure filter; external filling connection GEKA coupling for main tank and fresh water tank; filling with spray pump via selection valve; single-lever operation in the pressure area; indirect level indicator; induction hopper with hopper rinse, canister flushing and Proflow nozzle in the outlet; internal cleaning of tank; variable agitation; single nozzle holder; section control with pressure balancing; circulation up to the section control valves on the centrepiece; receiving pockets for fork lifts.

All specifications, dimensions and weights are subject to continuous technical development and are therefore not binding. The weight specifications always refer to the basic equipment. Subject to change.



# Service decides



When you have bought a machine from LEMKEN, the well-known, almost proverbial LEMKEN service starts. 17 customer-oriented factory branches and outdoor storage areas in Germany as well as our own sales companies and importers in more than 40 countries, and a strong dealer network, ensure that machines and spare parts are supplied quickly.

If a part is not in stock, it can be delivered to the customer within 24 hours via the LEMKEN logistics centre which is manned round-the-clock 365 days a year.

### **Knowledge from the LEMKEN specialist**

Well trained customer service technicians are available to farmers, contractors and trade, who are using machinery for the first time, as well as for professional maintenance and repairs. Thanks to regular training courses, LEMKEN customer service is always up to date with the latest LEMKEN technology.



## **Original spare parts from LEMKEN**

LEMKEN wearing parts are designed for a maximum service life. High-quality materials, the latest production methods, and an intensive quality control ensure a long service life. Therefore, all original spare parts bear a unique identification with the registered LEMKEN trademark. Original spare parts can be ordered at any time online on the Internet via the LEMKEN information and ordering system.



# LEMKEN

As professional crop production specialists, LEMKEN is one of the leading companies in Europe, with over 850 employees worldwide, achieving sales revenues of more than EUR 200 m. Originally founded in 1780 as a blacksmith's forge, the family company produces high-quality and high-performance farm machinery for soil cultivation, sowing and plant protection at its German headquarters in Alpen and at its two other production sites in Fohren and Meppen. 65 percent of the approximately 11,000 machines per year are exported.



**LEMKEN in Alpen/Germany**



**Mounted ploughs**



**Hybrid ploughs**



**Semi-mounted ploughs**



**Furrow presses**



**Front presses**



**Compact combinations**



**Seedbed combinations**



**Power harrows**



**Compact disc harrows**



**Cultivators**



**Subsoilers**



**Seed drills**



**Drill combinations**



**Mounted field sprayers**



**Trailed field sprayers**

LEMKEN GmbH & Co. KG  
 Weseler Straße 5  
 46519 Alpen  
 Telefon +49 2802 81 0  
 Telefax +49 2802 81 220  
 lemken@lemken.com  
 www.lemken.com

Your LEMKEN dealer:

